

## Transcutaneous Electrical Nerve Stimulation: Basic Science Mechanisms and Clinical Effectiveness

Kathleen A. Sluka\* and Deirdre Walsh†

**Abstract:** Transcutaneous electrical nerve stimulation (TENS) is used clinically by a variety of health care professionals for the reduction of pain. Clinical effectiveness of TENS is controversial, with some studies supporting whereas others refute its clinical use. Although used by health professionals for decades, the mechanisms by which TENS produces analgesia or reduces pain are only recently being elucidated. This article describes the basic science mechanisms behind different frequencies of TENS stimulation. Specifically, we describe the literature that supports the use of different frequencies and intensities of TENS. We further describe theories that support the use of TENS such as the gate control theory and the release of endogenous opioids. The literature that supports or refutes each of these theories is described. We also review the clinical literature on TENS effectiveness and elucidate the problems with clinical research studies to date. In conclusion, TENS is a noninvasive modality that is easy to apply with relatively few contraindications. However, the clinical efficacy of TENS will remain equivocal until the publication of sufficient numbers of high quality, randomized, controlled clinical trials.

© 2003 by the American Pain Society

*Key words:* Pain, hyperalgesia, analgesia, electrical stimulation

### What Is TENS?

Transcutaneous electrical nerve stimulation (TENS) is defined by the American Physical Therapy Association as the application of electrical stimulation to the skin for pain control. TENS is noninvasive, inexpensive, safe, and easy to use.<sup>4</sup> Electricity has been used for thousands of years for relief of pain, with the first written documentation by Aristotle.<sup>38</sup>

In the mid-1800s and early 1900s a number of physicians and dentists reported the use of electricity as an analgesic and anesthetic. However, electrical stimulation for pain relief was not fully accepted by the medical field until the publication by Wall and Sweet<sup>90</sup> in 1967 in response to the gate theory of pain.<sup>51</sup> Wall and Sweet

demonstrated that high frequency (100 Hz) stimulation at an intensity that activates large afferent fibers reduced neuropathic pain in 8 patients. Although used clinically for more than 30 years, the mechanisms by which TENS produces pain relief were not known. Several theories support the use of TENS including the gate control theory of pain and release of endogenous opioids. This review will focus on the current and previous literature that has begun to elucidate the basic science mechanisms of TENS and how these mechanisms can be applied to the clinic. We will also review the clinical literature on TENS and elucidate the problems with clinical research studies to date.

Clinically, TENS is applied at varying frequencies, intensities, and pulse durations of stimulation. Frequency of stimulation is broadly classified as high frequency (>50 Hz), low frequency (<10 Hz), or burst (bursts of high frequency stimulation applied at a much lower frequency) TENS. Intensity is determined by the response of the patient as either sensory level TENS or motor level TENS. In addition, some clinicians use stimulation below a sensory intensity termed microcurrent electrical stimulation. To date, there are no data to support microcurrent electrical stimulation. With sensory level TENS the voltage (ie, amplitude) is increased until the patient feels a comfortable tingling (perceived with high frequency) or tapping (perceived with low frequency) sensation without motor contraction. This amplitude is referred to

Received September 12, 2002; Revised November 13, 2002; Accepted November 13, 2002

From the \*Physical Therapy and Rehabilitation Sciences Graduate Program, Neuroscience Graduate Program, Pain Research Program, University of Iowa, Iowa City, IA, and †Rehabilitation Sciences Research Group, School of Rehabilitation Sciences, University of Ulster, Ulster, United Kingdom.

Supported by the Arthritis Foundation and K02 AR02201

Address reprint requests to Kathleen A. Sluka, PT, PhD, 100 Medical Education Building, 1-242, Physical Therapy and Rehabilitation Science Graduate Program, University of Iowa, Iowa City, IA 52242. E-mail: kathleen-sluka@uiowa.edu

© 2003 by the American Pain Society

1526-5900/2003 \$30.00 + 0

doi:10.1054/jpai.2003.434

as low intensity. With motor level TENS the intensity is increased to produce a motor contraction. Usually the intensity is increased to the maximal level before becoming noxious. This is referred to as high intensity TENS. In general, high frequency TENS is applied at low intensities and is referred to as conventional TENS. In contrast, low frequency TENS is typically applied at high intensities so that a motor contraction is produced. This mode of stimulation is referred to as strong, low rate, or acupuncture-like TENS. Stimulus strength duration curves for application of TENS to the skin demonstrate that sensory level TENS occurs with the lowest amplitude, followed by motor contraction and then noxious sensation.<sup>63,91</sup>

Numerous studies have attempted to determine the effectiveness of TENS treatment for people with a variety of pain conditions.<sup>52,56,57,62,85</sup> However, the clinical literature on TENS is controversial. Although the majority of studies support the use of TENS, a number of studies refute its effectiveness. Several factors may contribute to this controversy. Many early studies did not use a placebo control but rather compared their results to patients who did not receive any treatment. TENS itself has a significant placebo effect. A number of studies compared the effectiveness of TENS to other treatments including modalities, exercise, and various pharmacologic treatments. Although TENS may not be more effective than these treatments, it may be equally effective. Stimulation parameters, ie, frequency, intensity, and pulse duration, are commonly not specified or not kept constant among patients within a given study. Placement of electrodes varies considerably between studies such that some studies place electrodes at the site of injury, some within the dermatome, and others proximal to the site of injury. Furthermore, patient populations vary between studies and within studies, making it difficult to interpret the appropriate patient population who would benefit from TENS treatment. Last, a variety of different outcome measures are used to assess the effectiveness of TENS including subjective pain rating scales, joint function, analgesic intake, primary hyperalgesia (increased responsiveness to nociceptive stimuli at the site of injury), secondary hyperalgesia (increased responsiveness to nociceptive stimuli outside the site of injury), and various questionnaire outcomes measures. It is entirely possible that TENS is effective on some measures of pain or function and ineffective for others. To overcome many of these shortcomings in the clinical research design, animal models of pain have been used to assess effects of varying parameters and different outcome measures. Animal models minimize the placebo effect, control the extent and type of injury, and maintain application of TENS constant between subjects. In addition, animal models of pain allow one to assess the neurobiologic mechanisms by which TENS produces a reduction in pain behaviors.

## TENS in Animal Models

Several animal models of pain exist, are used to measure effectiveness of pharmaceutical agents, and mimic clinical conditions.<sup>18</sup> These models can broadly be classi-

fied as acute pain models, inflammatory pain models, and neuropathic pain models. TENS has been used in all of these conditions. Acute pain models have been used for decades as screening tools to test the efficacy of pharmacologic agents and do not produce tissue injury.<sup>22</sup> The response to noxious heat, mechanical or electrical stimulation is assessed in acute pain models. Models of tissue injury were developed later to more directly measure pain that might be similar to clinical syndromes. Hyperalgesia, an increased response to a noxious stimulus, occurs in response to tissue injury.<sup>95</sup> Hyperalgesia can occur at the site of injury, termed primary hyperalgesia, and is thought to reflect changes in primary afferent fibers, although central neuronal changes will influence primary hyperalgesia.<sup>95</sup> Secondary hyperalgesia develops outside the site of injury and is thought to reflect an increase in central neuron excitability.<sup>95</sup> Both primary and secondary hyperalgesia occur in response to heat and mechanical stimuli after tissue injury.<sup>26,41,43,61,81</sup> Carrageenan can be injected into the paw or knee joint to produce an acute inflammatory event resulting in hyperalgesia.<sup>81</sup> The carrageenan model has been well characterized neurophysiologically with increased firing and sensitivity of nociceptors, increased receptive field size of spinal neurons, and increased firing and sensitivity of spinal dorsal horn neurons.<sup>69</sup> Injection of complete Freund's adjuvant, either systemically or into a joint, is a model of chronic inflammation similar to rheumatoid arthritis.<sup>18</sup> Several models of neuropathic pain have been developed and are used extensively. The 2 most common models are the Bennett model induced by making loose ligations around the sciatic nerve<sup>5</sup> and the Chung model induced by making tight ligations around the spinal nerves.<sup>40</sup> Each of these neuropathic pain models produces a measurable long-lasting hyperalgesia and changes in the central nervous system.

Effects of TENS were analyzed in several animal models. Early studies used acute tests such as the tail flick response to noxious heat and hot plate test to examine the effects of TENS. Specifically, Woolf et al<sup>96,97</sup> demonstrated that the tail flick latency to heat increased (ie, analgesia) after treatment with electrical stimulation at high frequencies that activate A fibers (Fig 1A). Inhibition by TENS still occurs in animals that have been spinalized to remove descending inhibition.<sup>73,97</sup> However, the inhibition of the tail flick reflex by high frequency TENS is not as great in spinalized animals as compared to intact animals, suggesting both segmental and descending inhibition are involved in the analgesia produced by high frequency TENS<sup>97</sup> (Fig 1A).

Another measure of nociceptive activity is to record activity of ventral roots or of neurons located in the spinal cord. Neurons in the spinal cord that respond to noxious stimuli include (1) high threshold neurons, which exclusively respond to noxious stimuli, and (2) wide dynamic range neurons, which respond to both innocuous and noxious stimulation.<sup>95</sup> A-fiber conditioning stimulation (TENS) reduces (1) activation of ventral roots by C-fiber stimulation<sup>73</sup> and (2) activity of dorsal horn neurons.<sup>24,25,44</sup> Spinothalamic tract cells transmit pain and

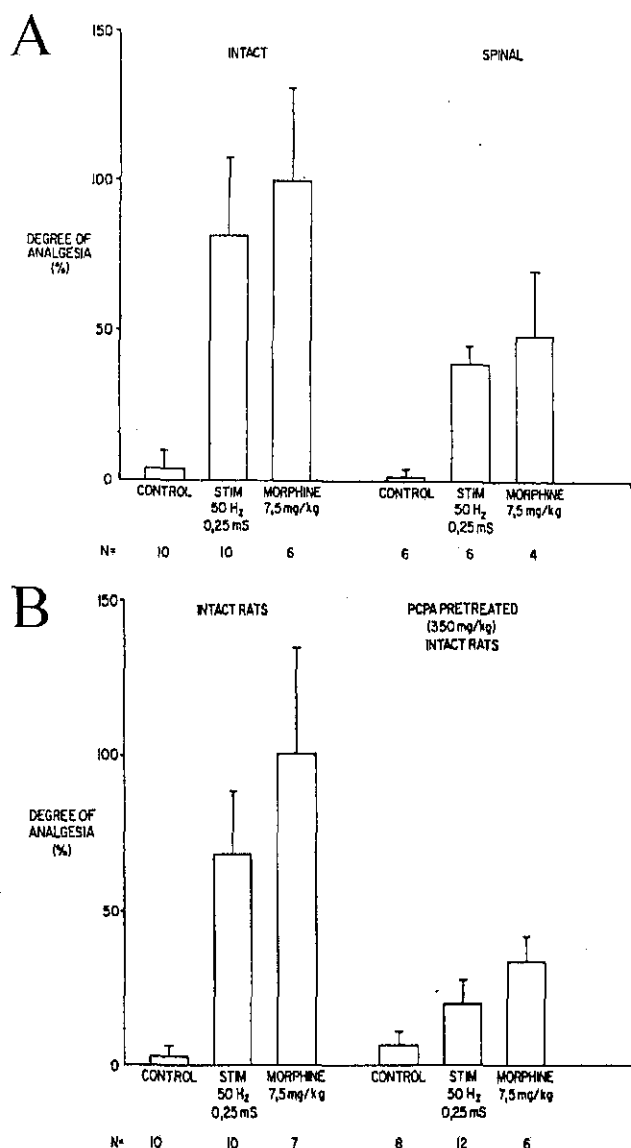

**Figure 1.** (A) Bar graphs represent the analgesia produced by TENS and morphine in the tail flick test for animals that are intact and those that were spinalized. Fifty-hertz electrical stimulation produced an increase in the tail flick latency similar to that of systemic morphine. Spinal transection reduced the amount of inhibition by electrical stimulation or morphine by approximately 50%. (B) Bar graphs represent the analgesia produced by 50-Hz electrical stimulation or morphine in the tail flick test in intact animals. Animals pretreated with para-chlorophenylalanine (PCPA) to deplete the neurotransmitter serotonin (5-HT) showed a significant reduction in the amount of analgesia produced by either electrical stimulation or morphine. Control animals did not receive electrical stimulation or morphine but were still spinalized or pretreated with PCPA. Reprinted from Woolf CJ, Mitchell D, Barrett GD: Antinociceptive effect of peripheral segmental electrical stimulation in the rat. *Pain* 8:237-252, 1980 with permission of Elsevier Science Publishers.

temperature information from the spinal cord to the thalamus and are both high threshold and wide dynamic range neurons.<sup>95</sup>

The spontaneous activity and noxious input to spinothalamic tract cells are inhibited by low and high fre-

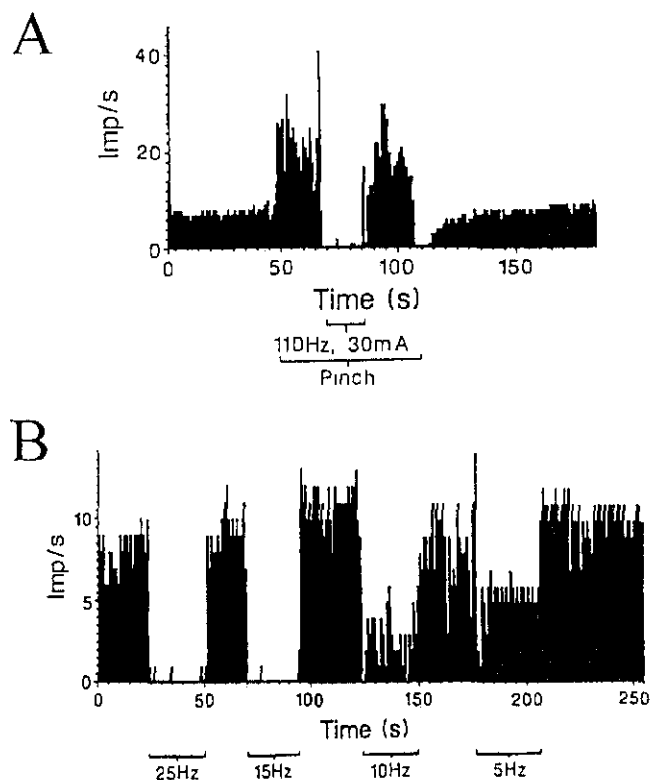

**Figure 2.** Oscilloscope trace of action potentials from a spontaneously firing dorsal horn neuron that responds to noxious stimuli. Spontaneous firing of the neuron is reduced by TENS. Increasing frequency of stimulation results in a greater inhibition of spontaneous activity. The bottom figure shows the response of a dorsal horn neuron that responds to pinch. An increase in the number of action potentials occurs when a noxious mechanical stimulus is applied to the skin (pinch, long bar). TENS application to the receptive reduces the pinch response of the neuron. Once TENS is removed, the pinch response returns. Reprinted from Garrison DW, Foreman RD: Decreased activity of spontaneous and noxiously evoked dorsal horn cells during transcutaneous electrical nerve stimulation (TENS). *Pain* 58:309-315, 1994 with permission of Elsevier Science Publishers.

quency TENS.<sup>24,25,44</sup> However, Lee et al<sup>44</sup> demonstrated that low frequency TENS produced a greater inhibition than high frequency TENS. Further, intensity at 3× the threshold to activate Aβ fibers was ineffective, but increasing to a strength that activated Aδ nociceptors produced a greater inhibition.<sup>44</sup> In contrast, Garrison and Foreman<sup>25</sup> recorded from dorsal horn neurons in cats and examined the effect of varying frequency, intensity, and pulse duration on the inhibition of dorsal horn cell activity by TENS (Fig 2). Specifically, increasing intensity, frequency, or pulse duration increases the amount of inhibition of dorsal horn neurons produced by TENS. In addition, the effects of TENS on dorsal horn cells are short lasting, returning to normal after removal of the TENS. Similarly, increasing intensity of stimulation to activate Aδ fibers increases the inhibition of the flexion reflex with either low or high frequency stimulation parameters.<sup>73,74</sup> These data suggest that high and low frequency TENS are effective, increasing intensity increases inhibition, and the effects of TENS are short lasting.

In one study, effect of electrode placement was evaluated by placing electrodes within the receptive field for a spinothalamic tract neuron, outside the receptive field of the neuron but on the same limb, and at the mirror site.<sup>44</sup> The greatest degree of inhibition of spinothalamic tract cell activity occurred with electrodes placed within the receptive field for the neuron, and only minimal inhibition occurred when placed on the same hind limb but outside the receptive field.<sup>44</sup> Behaviorally, in animals without tissue injury, TENS applied to the knee joint has no effect on the paw withdrawal latency.<sup>77</sup> These data suggest that electrode placement is important and that the greatest effect will occur if given at the site of injury at which one would be expected to affect the receptive fields of sensitized neurons.

TENS, however, is not given to people without pain so later studies began to use well-established animal models of pain to test TENS effectiveness. After injection of carrageenan into the paw a localized acute inflammatory event occurs. Response to heat and mechanical stimuli on the paw at the site of the inflammation is used to measure primary hyperalgesia. Modulation of frequency (4 vs 100 Hz), intensity (sensory vs motor), or pulse duration (100 vs 250  $\mu$ sec) demonstrated a frequency, but not intensity or pulse duration, dependent effect on primary hyperalgesia to mechanical and heat stimuli in animals with carrageenan paw inflammation.<sup>28</sup> In this study only animals treated with high frequency TENS at the site of inflammation showed a reduction in primary hyperalgesia, and this reduction was minimal.<sup>28</sup> In contrast, injection of kaolin and carrageenan into the knee joint is used to measure secondary hyperalgesia on the paw. Treatment of the inflamed knee joint with either high or low frequency TENS at sensory intensity produced an equal and dramatic reversal of heat and mechanical hyperalgesia.<sup>41,77</sup> Increasing intensity did not further increase the analgesia produced by either high or low frequency TENS.<sup>41</sup> Interestingly, there is a long-lasting reduction in hyperalgesia that persists for 12 to 24 hours for both primary and secondary hyperalgesia models with carrageenan inflammation.<sup>41,77</sup> The increased responsiveness of dorsal horn neurons to innocuous and noxious mechanical stimuli that occurs after inflammation is equally reduced after either high or low frequency TENS treatment applied to the inflamed paw.<sup>46</sup> This reduction in sensitization of high threshold and wide dynamic range dorsal horn neurons parallels the effects of TENS on secondary hyperalgesia.<sup>46</sup> When measuring secondary hyperalgesia or dorsal horn neuron activity, responses are reduced back toward preinflammation responses by TENS but not beyond basal responses.

With the Bennett model of neuropathic pain, Somers and Clemente<sup>84</sup> demonstrated that high frequency, low (sensory) intensity TENS stimulation over the paraspinal musculature reduced heat but not mechanical hyperalgesia that normally occurs in this model. This inhibition of heat hyperalgesia only occurs if TENS was started the first day after injury but not if started 3 days after injury.<sup>84</sup> Following spinal nerve ligation (Chung model of neuropathic pain), Leem et al<sup>45</sup> recorded responses of

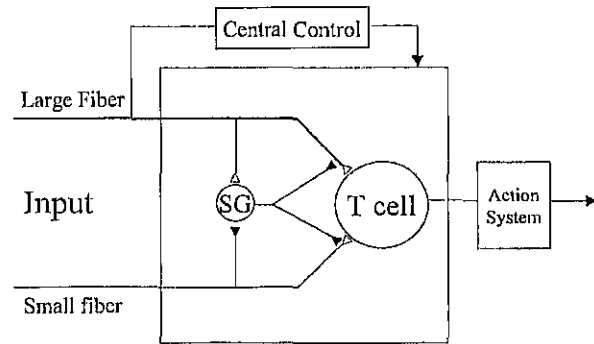

**Figure 3.** Diagram showing the gate control theory of pain as originally described by Melzack and Wall, 1965. T cell is an ascending neuron that could be from the spinothalamic, spinoreticular, or spinomesencephalic tract. SG is a neuron in the substantia gelatinosa (laminae II) of the spinal cord dorsal horn. Open triangles represent excitatory synapses and closed triangles represent inhibitory synapses. Large Fiber represents input from large diameter primary afferent fibers in the peripheral nervous system, and Small fiber represents input from small diameter nociceptive primary afferent fibers in the peripheral nervous system. The general concept is that small diameter fibers excite cells in the spinal cord that send information to higher centers for the perception of pain. Large diameter fiber input reduces noxious input of nociceptors by activation of inhibitory neurons in the substantia gelatinosa of the spinal cord. Reproduced from Melzack R, Wall PD: Pain mechanisms: A new theory. *Science* 150:971-978, 1965 with permission of the American Association of the Advancement of Science.

dorsal horn neurons before and after application of low frequency, motor intensity TENS and compared these effects to those from animals without tissue injury. TENS reduced the responsiveness to noxious mechanical stimulation of dorsal horn neurons in both normal and neuropathic animals. However, the responsiveness of spinal neurons to innocuous mechanical stimulation was only inhibited by TENS in neuropathic animals.<sup>45</sup>

## Theories of TENS

Several theories are used to support the use of TENS. The gate control theory of pain is most commonly used to explain the inhibition of pain by TENS (Fig 3). According to the gate control theory of pain, stimulation of large diameter afferents by TENS inhibits nociceptive fiber evoked responses in the dorsal horn.<sup>51</sup> The gate control theory is thought to involve segmental inhibition by using neurons located in the substantia gelatinosa of the spinal cord dorsal horn. However, the original theory did suggest that descending inhibitory pathways might exist and that these spinal neurons are under descending influences. Specific neurotransmitters or their receptors were not suggested at the time because we were only beginning to understand the pharmacology of the nervous system. Thus, the gate control theory can be interpreted broadly. There are now much more detailed data on mechanisms of actions of TENS that include anatomic pathways, neurotransmitters and their receptors, and the types of neurons involved in the inhibition. Several studies support segmentally mediated inhibition mecha-

nisms in TENS analgesia. High frequency TENS inhibition is partially prevented by spinalization, which removes descending inhibitory influences.<sup>97</sup> However, a significant amount of inhibition remains after spinalization. Thus, TENS appears to produce both segmental and descending inhibition.

Alternatively, Campbell and Taub<sup>8</sup> suggested that high frequency stimulation by TENS results in conduction block or fatigue of A $\delta$  fibers. However, Janko and Trontelj<sup>35</sup> and Lee et al<sup>44</sup> demonstrated that afferent barrage evoked by painful stimuli is intact during and after TENS. Thus, even high frequency TENS stimulation was unable to block input from the peripheral site to the central nervous system. Further, the antihyperalgesic effects of TENS outlast the stimulation time by 8 to 24 hours, suggesting mechanisms other than blockade of input from the periphery.

A role for adenosine in large fiber stimulation by vibration analgesia has been suggested by Salter and Henry.<sup>67</sup> Because TENS presumably activates large fibers, it follows that adenosine may play a role. In support of adenosine, if human subjects were given caffeine (which blocks adenosine receptors) before TENS, the analgesia produced by TENS was significantly reduced compared to placebo.<sup>50</sup>

Last, release of endogenous opioids has been used to explain the actions of TENS, particularly low frequency stimulation. Recent data support this theory for low frequency TENS as well as for high frequency TENS stimulation.<sup>37,79</sup>

There are 3 types of opioid receptors,  $\mu$ ,  $\delta$ , and  $\kappa$ .<sup>23</sup> These are located peripherally, in the spinal cord and in areas involved in descending inhibition including the nucleus raphe magnus in the rostral ventral medulla (RVM) and the periaqueductal gray (PAG).<sup>23</sup> The PAG sends projection to the RVM, which in turn sends projections to the spinal dorsal horn<sup>23</sup> (Fig 4). Stimulation of the PAG or the RVM produces inhibition of dorsal horn neurons including spinothalamic tract cells.<sup>23</sup> It is commonly accepted that opioid mediated inhibition produces its effects through activation of the PAG-RVM pathway.<sup>23</sup> Further, the RVM pathways use serotonin as a neurotransmitter.<sup>23</sup> Another common inhibitory pathway is from the pontine noradrenergic cells groups, A6 (locus caeruleus) and A7 (locus subcaeruleus).<sup>23</sup> These pontine neurons use the neurotransmitter noradrenaline and activate  $\alpha$ -2 receptors spinally to produce inhibition of dorsal horn neurons.<sup>23</sup>

Concentrations of  $\beta$ -endorphins increase in the bloodstream and cerebrospinal fluid of healthy subjects after administration of either high or low frequency TENS.<sup>31,66</sup> Increased concentrations of methionine enkephalin, a  $\delta$  opioid agonist, and dynorphin A, a  $\kappa$  opioid agonist, are observed in the lumbar cerebrospinal fluid after treatment of patients with either low or high frequency TENS, respectively.<sup>29</sup> This suggests that at the spinal level there are different opioids released with different stimulation frequencies and thus possibly different opioid receptors activated to produce analgesia with high or low frequency TENS. Taken together, these data indicate that

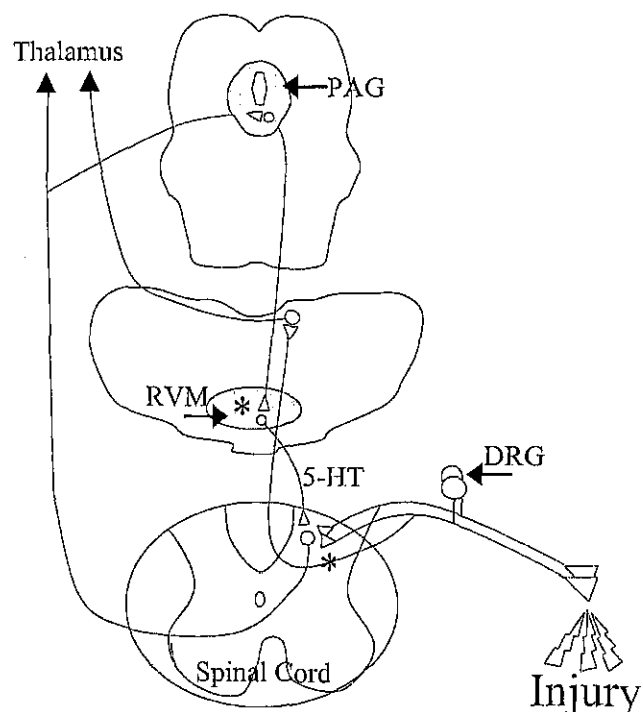

**Figure 4.** Diagram representing the descending inhibitory pathways. The PAG sends projections to the RVM, which then sends serotonergic (5-HT) projections to the spinal cord dorsal horn. Application of opioids (\*) into the PAG, RVM, or spinal cord results in analgesia and reduces pain. DRG, dorsal root ganglion.

several opioids and their receptors might be involved in relief of pain by TENS.

In an animal model of knee joint inflammation, secondary hyperalgesia is reversed completely by either low frequency (4 Hz) or high frequency (100 Hz) TENS at sensory intensities.<sup>79</sup> To test the role of opioid receptors in the reduction of hyperalgesia produced by TENS, opioid receptor antagonists were delivered directly to the spinal cord to block  $\mu$  (naloxone),  $\delta$  (naltrindole), or  $\kappa$  (norbinal) opioid receptors<sup>79</sup> (Fig 5). Low frequency, sensory intensity TENS antihyperalgesia was prevented by the blockade of  $\mu$  opioid receptors with naloxone, and high frequency, sensory intensity TENS antihyperalgesia was prevented by blockade of  $\delta$  opioid receptors with naltrindole<sup>79</sup> (Fig 5). Further studies tested the role of opioid receptors in areas of descending inhibition. Blockade of opioid receptors in the RVM showed a similar effect as observed by spinal blockade.<sup>37</sup> Specifically, blockade of  $\mu$  opioid receptors in the RVM prevented the antihyperalgesia by low frequency, sensory intensity TENS, and blockade of  $\delta$  opioid receptors prevented the antihyperalgesia produced by high frequency, sensory intensity TENS<sup>37</sup> (Fig 5). These data thus suggest that specific and different opioid receptors are activated by different frequencies of TENS such that  $\mu$  opioid receptors are involved in the antihyperalgesia produced by high frequencies and  $\delta$  opioid receptors are involved in the antihyperalgesia produced by low frequency TENS.

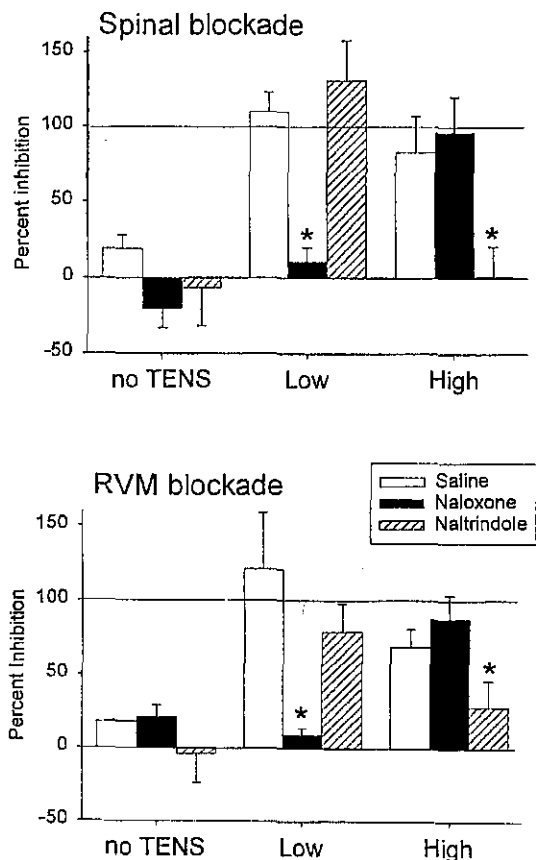

**Figure 5.** Bar graphs represent the percent inhibition of hyperalgesia following blockade of  $\mu$  opioid receptors with naloxone or  $\delta$  opioid receptors with naltrindole in the spinal cord (top panel) or RVM (bottom panel). Animals received no TENS, low frequency TENS (low), or high frequency TENS (high) at sensory intensities. Secondary hyperalgesia was induced by intra-articular injection of kaolin and carrageenan into the knee joint. A full reduction in hyperalgesia is 100% inhibition, and no change in hyperalgesia is 0% inhibition. In animals that did not receive TENS there was no change in the degree of hyperalgesia. Low and high frequency TENS with saline injected into either the spinal cord or RVM resulted in approximately 100% inhibition of hyperalgesia. Blockade of  $\mu$  opioid receptors with naloxone, but not  $\delta$  opioid receptors with naltrindole, in either the spinal cord or RVM prevented the antihyperalgesic effects of low frequency TENS. In contrast, blockade of  $\delta$  opioid receptors, but not  $\mu$  opioid receptors, prevented the antihyperalgesic effect of high frequency TENS.

Early clinical and basic studies support this view. Sjolund and Eriksson<sup>75</sup> used naloxone systemically to block opioid receptors in human subjects treated with either high or low frequency TENS. Doses used were at a range sufficient to block  $\mu$  opioid receptors. Their data showed that low frequency, but not high frequency, TENS was blocked by naloxone. This was followed by 2 animal studies, in which higher doses of naloxone could be administered to nonselectively block opioid receptors. These studies showed that high frequency TENS was reduced by systemic naloxone in doses sufficient to block  $\mu$ ,  $\delta$ , and  $\kappa$  opioid receptors.<sup>30,97</sup>

A role for descending inhibitory pathways is further supported by studies on serotonin, which is the neuro-

transmitter located in the PAG-RVM pathway. Depletion of serotonin reduces the antinociceptive effect of high frequency stimulation in the intact but not in the spinalized animal.<sup>97</sup> Electrical stimulation induced antinociception is significantly enhanced by administration of L-5-hydroxytryptophan, a serotonin precursor, and abolished by the opiate receptor antagonist, naloxone, and the serotonin receptor antagonist, methysergide.<sup>72,97</sup> Thus, TENS inhibition involves activation of descending inhibitory pathways involving the RVM and using serotonin and opioids to reduce pain and hyperalgesia.

TENS could potentially have local peripheral or autonomic effects. Electrical stimulation in intensities that could activate A $\delta$  fibers modifies local blood flow and vascular resistance.<sup>68</sup> Transient increases in blood flow with low frequency, burst mode (2 Hz) TENS were observed at the area of stimulation if intensity was 25% above the motor threshold but not just below (sensory intensity) or just above motor threshold.<sup>71</sup> Similarly, high frequency TENS stimulation at intensities just above or below motor threshold did not affect local blood flow.<sup>32</sup> With laser Doppler imaging, increases in blood flow were observed with either low or high frequency TENS at an intensity that was felt but not painful (10 to 15 mA).<sup>94</sup> In rats with nerve injury, low frequency, motor intensity TENS reduced mechanical hyperalgesia and cold allodynia. The effect of TENS on cold allodynia, but not mechanical hyperalgesia, was reduced by systemic phentolamine to block alpha-adrenergic receptors, suggesting activation of sympathetic noradrenergic receptors may mediate TENS effects.<sup>54</sup> However, effects of phentolamine could block central receptors, and future studies should address this issue. Substance P in dorsal root ganglia neurons and spinal cord dorsal horn is reduced by high frequency TENS in animals injected with the inflammatory irritant, formalin.<sup>64</sup> Thus, evidence is beginning to emerge that some of the analgesic effects of TENS may be mediated through actions on primary afferent fibers and modulation of autonomic activity.

## What Does This Mean in the Clinic and Suggestions for Future Studies

Clinically, TENS will more than likely not be the only treatment the patient is receiving. TENS is a complementary and adjunct treatment to control pain. Medically, the patient will more than likely be taking prescription medications such as nonsteroidal anti-inflammatories, opioids (fentanyl, oxycodone hydrochloride), alpha-adrenergic agonists (clonidine), or muscle relaxants (cyclobenzaprine). The most common procedural interventions in physical therapy are therapeutic exercise and functional training.<sup>1</sup> Physical therapists who treat pain, particularly chronic pain, use a combination of exercise and functional training. Electrotherapeutic modalities, or TENS, are used by physical therapists as an adjunct to modulate and reduce pain, and use of TENS in the absence of other interventions is not considered physical therapy.<sup>1</sup> However, in some conditions and patients, pain limits the ability of a patient to perform an ade-

quate exercise program. Once the pain is controlled, the patient should be better able to perform an active exercise program, activities of daily living, or return to work. Understanding the mechanisms will better assist the clinician in the appropriate choice of pain control treatment. Parameters of stimulation can be based on the basic knowledge, and use of a particular modality such as electrical stimulation can be used in a more educated manner. Specific examples will be given below to address these issues.

Use of TENS (in combination with other therapies) will allow patients to increase activity level, reduce hospital stay, and improve function. Indeed, treatment with TENS increases joint function in patients with arthritis.<sup>2,42,47,48,98</sup> In patients with chronic low back pain, improvements on the physical and mental component summary on the SF-36 quality of life survey occur with TENS.<sup>27</sup> Postoperative TENS treatment in patients after thoracic surgery reduces recovery room stay and improves pulmonary function as measured by postoperative PO<sub>2</sub>, vital capacity, and functional residual capacity when compared to sham controls.<sup>3,92</sup> Thus, decreasing pain with TENS increases function and allows the patient to tolerate other therapies and activities, resulting in an improved quality of life.

One should be aware of the medication a person is taking and the effects of these medications on the effects of TENS. By understanding the mechanisms of action of TENS, more appropriate treatment strategies can be tried. If a patient is taking opioids, currently those available that activate  $\mu$  opioid receptors, high frequency TENS may be more appropriate. Repeated application of opioid produces tolerance to the opioid such that a higher dose is necessary to produce the same effect. This is based on the fact that low frequency TENS, but not high frequency, is ineffective if given in animals tolerant to morphine.<sup>80</sup> Clinically, Solomon et al<sup>83</sup> demonstrated that in patients who had taken enough opioids to become tolerant to morphine, TENS was ineffective in reducing postoperative pain. However, parameters of stimulation were not given, and this needs to be more fully addressed. Furthermore, it follows that repeated treatment with the same frequency of TENS would produce tolerance to its analgesic effects. Indeed, daily treatment with either low frequency or high frequency TENS in animals with knee joint inflammation produces tolerance to TENS and a cross-tolerance to spinally administered  $\mu$  or  $\delta$  opioid agonists, respectively.<sup>13</sup> Thus, TENS is ineffective if morphine tolerance is present and shows opioid tolerance with repeated use.

It might be possible to enhance the effects of TENS clinically if given in combination with certain agonists or antagonists. High frequency TENS only partially reduces primary hyperalgesia, and low frequency TENS is ineffective on primary hyperalgesia.<sup>28</sup> However, either high or low frequency TENS is more effective in reducing primary hyperalgesia if given in combination with acute administration of morphine<sup>76</sup> or clonidine.<sup>78</sup> Synergism between alpha-adrenergic agonists and opioid agonists ( $\mu$  and  $\delta$ ) has been shown in pharmacologic studies.<sup>20,21</sup>

Because low frequency TENS works by activation of  $\mu$  opioid receptors, this enhanced antihyperalgesia is probably a result of synergistic interaction between alpha 2-adrenergic receptors and endogenous opioids. Use of TENS in combination with morphine or clonidine should reduce the dosage of morphine or clonidine necessary to reduce hyperalgesia and thus reduce side effects of morphine and increase analgesia. In fact, clinically, intake of opioids is reduced in patients using TENS.<sup>27,65,82,83,92,93</sup> Further, there is a reduction in nausea, dizziness, and pruritus associated with morphine intake.<sup>92</sup>

Animal studies suggest that TENS would be more effective for referred pain or secondary hyperalgesia than for primary hyperalgesia. This has yet to be determined clinically. In clinical studies, one should use a number of assessments for measuring the effectiveness of TENS. It seems clear that there are a variety of measurements that could be assessed in the pain patient and that TENS may not work equally well on all of these measures.

Therefore, understanding the neurotransmitters and pathways involved in TENS antihyperalgesia could help explain conflicting data with respect to the patient population studies and TENS. It will further assist the clinician in the treatment choice for a particular patient. The clinical use of TENS and further clinical outcome studies should be carefully evaluated with respect to the current medication of the patient.

Thus, future clinical studies need to be performed to confirm these animal data to provide a solid evidence base for the use of TENS. Clearly all patients might not respond to TENS treatment. Some considerations to take into account would be which frequency of TENS to use. Combinations of commonly administered pharmaceutical agents and TENS should be addressed in a clinical population.

## The Clinical Efficacy of TENS

Many of the early publications on TENS were either anecdotal or case reports and did not involve randomized controlled trials (RCTs). An RCT is a trial in which patients are randomly allocated to different treatment regimens, eg, active treatment, placebo, or control.<sup>19</sup> Blinding is a very important factor in the design of an RCT. This refers to whether the participants, those administering the interventions, and those assessing the outcomes are blinded to group assignment.<sup>53</sup> A single blind trial is one in which 1 group of individuals involved in the trial do not know the identity of the intervention that is given to the participant; this is usually the participants or the investigators assessing the outcomes. A double blind trial is one in which 2 groups of individuals involved in the trial do not know the intervention given to each participant; usually these 2 groups are the participants and the investigators who are assessing the outcomes.<sup>34</sup> Although the number of clinical trials on TENS has increased considerably during the past several years, there is still a need for rigorously conducted RCTs to determine its efficacy for acute and chronic pain conditions and, indeed, its nonanalgesic effects. The RCT is

**TABLE 1. Summary of Outcomes of TENS Systematic Reviews**

CONDITION	AUTHORS	NUMBER OF STUDIES INCLUDED	OUTCOME
Chronic pain	Carroll et al, 2001	19	Inconclusive
Chronic low back pain	Milne et al, 2002	5	No evidence to support TENS
Primary dysmenorrhea	Proctor et al, 2001	9	High frequency TENS more effective than placebo; low frequency TENS no more effective than placebo
Labor pain	Carroll et al, 1997	10	TENS has no significant effect
Post operative pain	Carroll et al, 1996	17	In 15 of 17 RCTs, TENS had no benefit over placebo
Knee osteoarthritis	Osiri et al, 2001	7	Conventional TENS and acupuncture-like TENS effective over placebo
Post-stroke shoulder pain	Price and Pandyan, 2000	4	Inconclusive

TENS, transcutaneous electrical nerve stimulation; RCTs, randomized controlled trials.

regarded as the gold standard in clinical trials of efficacy<sup>70</sup> and should therefore be viewed as the method of choice for evaluating a modality such as TENS.

One of the quickest methods of reviewing the clinical research on TENS is to read a recent systematic review. Systematic reviews should ideally provide an objective summary of the current literature on the chosen topic. However, some concerns have been raised about the methods involved in determining their outcome; therefore, perhaps the best way to regard these reviews is that "they may not be correct all of the time but they give a good guide most of the time."<sup>16</sup> Systematic reviews involve the retrieval of relevant studies that have been selected according to certain inclusion criteria and using predefined criteria lists such as the Jadad, Delphi, or Maastricht to score the quality of the study.<sup>17,33,89</sup> The following items are used to rate the study's methodologic quality: randomization, blinding, withdrawals, analysis and bias. However, the reader should be aware that different criteria lists do not always provide similar results when applied to the same trials. Verhagen et al<sup>88</sup> compared the outcome of 3 criteria lists on a data set of 21 studies and highlighted several differences between them that affected their respective ranking of the studies. With this warning in mind, Table 1 provides a summary of the key systematic reviews on the effectiveness of TENS published during the past several years, each of which will be discussed in more detail below.

### Chronic Pain

Berman and Bausell<sup>6</sup> conducted a survey on the use of nonpharmacologic therapies by pain specialists in 2000; they surveyed a sample of members of the International Association for the Study of Pain and reported that 77% of respondents indicated that they used TENS/other electromagnetic applications. The cost-effectiveness of TENS as a pain management technique has been highlighted by Chabal et al,<sup>12</sup> who interviewed a sample of 376 patients with chronic pain who were long-term users of TENS. After applying a cost simulation model to their data, they concluded that costs could be reduced up to 55% for pain medication and up to 69% for physical therapy/occupational therapy treatments.

TENS is viewed by many clinicians as primarily a modal-

ity for chronic pain conditions, and a wide range of surveys provide evidence to support this belief.<sup>12,36,87</sup> The systematic review by Carroll et al<sup>9</sup> included 19 RCTs on TENS and chronic pain that covered a broad range of conditions including rheumatoid arthritis, myofascial pain, diabetic neuropathy, and low back pain. Chronic pain was defined as pain of at least 3 months' duration. The most common outcome measure used in these studies was the 10-cm visual analogue scale (VAS). The authors thought that the methodologic quality of the studies was generally poor and reported that the results of their review were inconclusive. Several problems were highlighted such as inadequate reporting of the results and indeed the TENS treatments; the latter makes any future replication very difficult. Carroll et al suggested that we need large, randomized, multicenter, controlled trials in chronic pain.

### Chronic Low Back Pain

Only five RCTs were eligible for inclusion in the systematic review published by Milne et al<sup>52</sup> on TENS and chronic low back pain. Chronic low back pain was defined as low back pain over 3 months' duration. Interestingly, the application of TENS in the studies varied greatly, ranging from 1 treatment per day for 2 consecutive days to 3 treatments per day for 4 weeks. This variation in the actual method of applying TENS is a very good example of the lack of standardization generally observed across the RCTs published on TENS. Outcome measures included assessment of pain, function, well-being, disability, and satisfaction of care. The reviewers concluded that there was no evidence to support the use of TENS for the management of chronic low back pain but that there was a lack of data on type of application, treatment duration, and optimal frequencies and intensities. One study included in the review determined the best electrode placement site for each individual patient before the trial commenced.<sup>49</sup> This is a technique that is used in clinical practice and should also be used more frequently in clinical trials rather than selecting fixed points for all patients. Although this study did not score well overall in terms of the Jadad criteria list used, the TENS application technique was commendable. Similar findings were shown in a meta-analysis by Brosseau et



al.<sup>7</sup> With the same 5 RCTs as Milne et al<sup>52</sup> they found no difference between active TENS and sham TENS. They concluded that there was no evidence to support the use or nonuse of TENS for the treatment of chronic low back pain and future studies should include standardized outcome measures.

### **Post-Stroke Shoulder Pain**

Price and Pandyan<sup>59</sup> published a systematic review on the effect of electrical stimulation for post-stroke shoulder pain. They included various types of surface electrical stimulation including functional electrical stimulation and TENS; the stimulation parameters were different; therefore they were not comparing "like with like." Measurements of pain, range of passive humeral lateral rotation, motor score, and spasticity score were the outcome measures used in the 4 included studies. The authors expressed disappointment that so many of the published studies were case reports or else they used nonstandard outcome measures. They concluded that they were unable to make any definite conclusion about the 4 studies included in this review and emphasized the need for adequately powered RCTs to examine the role of electrical stimulation for this application.

### **Primary Dysmenorrhea**

Primary dysmenorrhea is the occurrence of painful menstrual cramps that are associated with ischemia of the uterus. The ischemia is believed to be linked to the presence of prostaglandins in the menstrual fluid that in turn cause hypercontractility of the myometrium. In the treatment of this condition, the TENS electrodes are typically placed over the abdomen or thoracic spine in areas related to the spinal nerve roots that receive nociceptive information from the uterus. In some cases, acupuncture points have been used, eg, B21, B29, ST36, and SP6.<sup>55</sup> Nine RCTs were selected for the systematic review carried out by Proctor et al,<sup>60</sup> which examined the effect of TENS and acupuncture on primary dysmenorrhea. Four of the studies used a crossover design that involved the subjects receiving all of the treatments during different menstrual cycles. The outcome measures typically included pain measurement and a record of menstrual symptoms. The findings of this review were that high frequency TENS was more effective than placebo and low frequency TENS was no more effective than placebo. In addition, there was insufficient evidence to compare high frequency with low frequency TENS. The reviewers queried whether the different approach to electrode placement in the studies contributed to treatment outcome, ie, the use of specific acupuncture points versus placing the electrodes over the site of pain. They also raised another interesting point with regard to the physiologic effects of TENS. Low frequency TENS typically produces muscle contractions, which may make it difficult for the user to wear TENS as a portable unit and to carry out daily activities, an issue that is not associated with high frequency TENS, which produces a comfortable paresthesia. Most of the studies involved applying TENS for a

short time period (eg, 30 minutes), but a few used much longer periods (8 hours). This factor may therefore affect subsequent evaluation of the treatment.

### **Knee Osteoarthritis**

Seven RCTs were eligible for inclusion in the systematic review by Osiri et al<sup>57</sup> on osteoarthritis and TENS. Both conventional and acupuncture-like modes of TENS were used in these studies. The length of treatment varied from one single 30-minute application to several applications daily for up to 6 weeks. Assessments of pain, stiffness, joint circumference, and muscle strength were used as outcome measures. The authors concluded that both conventional and acupuncture-like TENS were more effective than placebo for relief of pain but that the studies were heterogenous with different study designs and outcomes used. The reviewers called for standardized treatment protocols to be adopted for further TENS studies that would include electrode placement, treatment time, and parameters. However, the point raised with the low back pain studies applies to this condition also, ie, electrode placement should ideally be determined for each individual placement as performed in clinical practice. A recent article by Cheing et al,<sup>15</sup> which was not included in the systematic review by Osiri et al, has investigated the effect of TENS or isometric exercise on osteoarthritic knee pain. TENS was applied for 60 minutes 5 days per week for 4 weeks. The results showed a significant cumulative reduction in VAS in the TENS group and placebo group. The authors also reported that the decrease in pain was maintained at the 4-week follow-up only in the TENS and TENS plus exercise groups. Previous work by this research group has also reported a cumulative beneficial effect of daily application of TENS for both experimental pain and chronic low back pain.<sup>14,58</sup>

### **Acute Postoperative Pain**

Postoperative pain is an example of an acute pain condition in which TENS has been used with some success. In the postoperative situation, TENS is typically used as an adjunct to routine medication rather than as an isolated treatment. Application involves positioning sterile electrodes parallel to the incision with additional electrodes sometimes placed over the corresponding thoracic spinal nerves. The obvious advantages of controlling pain postoperatively include earlier mobilization, more effective deep breathing/coughing, which will lead to earlier discharge. Seventeen studies were included in the systematic review by Carroll et al.<sup>11</sup> Analgesic consumption and VAS were the 2 most common methods used to evaluate the treatments. This review is an important one because it clearly highlights the effect of lack of randomization in clinical trials. Of the 17 randomized studies that were included, 15 reported no beneficial effect of TENS, whereas 17 of the 19 nonrandomized trials that were excluded from the review showed positive effects for TENS. Schulz et al<sup>70</sup> have indicated that inappropriate blinding and lack of randomization can overestimate

treatment effects by 17% and 40%, respectively. This crucial finding should be borne in mind during the interpretation of published trials on TENS. Carroll et al reported that only 2 of the studies gave details of the randomization method, and the methods described were inadequate in both. They concluded that TENS was not effective for postoperative pain based on the 17 studies that they reviewed.

### Labor Pain

The application of TENS for labor pain involves positioning 2 pairs of electrodes over the spinal nerve roots of T10-L1 and S2-S4. The nociceptive information from the uterus, perineal structures, and cervix enters the spinal cord at these levels. Both continuous and burst TENS are used; continuous high frequency pulses are delivered during contractions and low frequency bursts are used between contractions. A "boost" control is used to switch between continuous and burst outputs. Carroll et al<sup>10</sup> included 10 RCTs in their systematic review. There was no consistency in the pain outcome measures used, which varied from a VAS, 3 or 4 point pain scale, and requirement for other analgesic interventions. Among the methodologic problems highlighted by the reviewers was the fact that 4 of the studies included in the review did not use any form of blinding. In addition, of the 7 studies that used placebo TENS, only 1 described the blinding procedure in sufficient detail to indicate that it may have been adequate. None of the 10 studies reported any significant differences between the con-

trols and active TENS treatments for the primary outcome measures used, leading the authors to suggest that TENS has no significant effect on labor pain. This negative finding is in contrast with the high level of consumer satisfaction associated with the use of TENS in labor reported in several studies including Kaplan et al<sup>39</sup> and van der Spank et al.<sup>86</sup>

The authors of the systematic reviews described above have used the gold standard of clinical research, the RCT, as the inclusion criterion for their individual reviews. However, it is obvious that many of the trials reviewed had considerable methodologic problems that led to a low score on the criteria list used. These problems included insufficient reporting of treatment techniques, inadequate treatment time, lack of standardized outcome measures, and inadequate blinding and randomization techniques. The Consolidated Standards of Reporting Trials (CONSORT) statement is a very useful checklist and diagram that was developed by an international group of clinical trialists, statisticians, epidemiologists, and biomedical editors. The aim of this statement was to help authors to improve reporting of RCTs.<sup>53</sup> The CONSORT should ideally be considered in the planning stage of future RCTs on TENS because it would provide researchers with a valuable tool for improving not just the quality of reporting but also the methodologic quality of the trial. It is only through high quality, adequately powered RCTs that the true clinical efficacy of TENS can be established.

### References

1. Guide to physical therapy practice, second edition. *Phys Ther* 81:9-744, 2001
2. Abelson K, Langley GB, Vlieg M, Wigley RD: Transcutaneous electrical nerve stimulation in rheumatoid arthritis. *N Z Med J* 96:156-158, 1983
3. Ali J, Yaffe CS, Sessle BJ: The effect of transcutaneous electric nerve stimulation on postoperative pain and pulmonary function. *Surgery* 89:507-512, 1981
4. Electrotherapy Standards Committee: Electrotherapeutic terminology in physical therapy (report). Section on clinical electrophysiology and American Physical Therapy Association, Alexandria, VA, 2001
5. Bennett GJ, Xie YK: A peripheral mononeuropathy in rat that produces disorders of pain sensation like those seen in man. *Pain* 33:87-107, 1988
6. Berman BM, Bausell RB: The use of non-pharmacological therapies by pain specialists. *Pain* 85:313-315, 2000
7. Brosseau L, Milne S, Robinson V, Marchand S, Shea B, Wells G, Tugwell P: The effectiveness of the transcutaneous electrical nerve stimulation (TENS) for the treatment of chronic low back pain: A meta-analysis. *Spine* 27:596-603, 2002
8. Campbell JN, Taub A: Local analgesia from percutaneous electrical stimulation. *Arch Neurol* 28:347-350, 1973
9. Carroll D, Moore RA, McQuay HJ, Fairman F, Tramer M, Leijon G: Transcutaneous electrical nerve stimulation (TENS) for chronic pain. *Chochrane Database Syst Rev*, 2001
10. Carroll D, Moore RA, Tramer MR, McQuay HJ: Transcutaneous electrical nerve stimulation does not relieve labor pain: updated systematic review. *Contemporary Issues in Obstetrics and Gynecology* September:195-205, 1997
11. Carroll D, Tramer M, McQuay HJ, Nye B, Moore A: Randomisation is important in studies with pain outcomes: Systematic review of transcutaneous electrical nerve stimulation in acute postoperative pain. *Br J Anesth* 77:798-803, 1996
12. Chabal C, Fishbain DA, Weaver M, Heine LW: Long-term transcutaneous electrical nerve stimulation (TENS) use: Impact on medication utilization and physical therapy costs. *Clin J Pain* 14:66-73, 1998
13. Chandran P, Sluka KA: Development of opioid tolerance with repeated TENS administration. *Pain* 102:195-201, 2003
14. Cheing G, Hui-Chan CW: Repeated applications of transcutaneous electrical nerve stimulation (TENS) produce cumulative effects on chronic clinical pain but not acute experimental pain in chronic low back pain patients. Abstracts of the 8th World Congress of the International Association for the Study of Pain. IASP Press, Seattle, WA, 1996, p 85
15. Cheing GLY, Hui-Chan CWY, Chan KM: Does four weeks of TENS and/or isometric exercise produce cumulative reduc-

- tion of osteoarthritic knee pain. *Clin Rehabil* 16:749-760, 2002
16. Crombie IK, McQuay HJ: The systematic review: A good guide rather than a guarantee. *Pain* 76:1-2, 1998
  17. de Vet H, de Bie RA, Van der Heijden GJMG, Verhagen AP, Sijpkens P, Knipschild PG: Systematic reviews on the basis of methodological criteria. *Physiother* 83:49-58, 1997
  18. Dubner R, Ren K: Assessing transient and persistent pain in animals, in Wall PD, Melzack R (eds): *Textbook of Pain*, chap 14. New York, NY, 1999, pp 359-369
  19. Earl-Slater A: *The Handbook of Clinical Trials and Other Research*. Radcliffe Medical Press, Oxon, UK, 2002
  20. Fairbanks CA, Nguyen HO, Grocholski BM, Wilcox GL: Moxonidine, a selective imidazoline- $\alpha_2$ -adrenergic receptor agonist, produces spinal synergistic antihyperalgesia with morphine in nerve-injured mice. *Anesthesiology* 93:765-773, 2000
  21. Fairbanks CA, Posthumus IJ, Kitto KF, Stone LS, Wilcox GL: Moxonidine, a selective imidazoline/ $\alpha_2$  adrenergic receptor agonist, synergizes with morphine and deltorphin II to inhibit substance P-induced behavior in mice. *Pain* 84:13-20, 2000
  22. Feldman RS, Meyer JS, Quenzer LF: *Principles of Neuropsychopharmacology*. Sunderland, MA, Sinauer Associates Inc, Publishers, 1997
  23. Fields HL, Basbaum AI: Central nervous system mechanisms of pain modulation, in Wall PD, Melzack R (eds): *Textbook of Pain*, chap 12. New York, NY, 1999, pp 243-257
  24. Garrison DW, Foreman RD: Decreased activity of spontaneous and noxiously evoked dorsal horn cells during transcutaneous electrical nerve stimulation (TENS). *Pain* 58:309-315, 1994
  25. Garrison DW, Foreman RD: Effects of prolonged transcutaneous electrical nerve stimulation (TENS) and variation of stimulation variables on dorsal horn cell activity. *Eur J Phys Med Rehabil* 6:87-94, 1997
  26. Garry MG, Hargreaves KM: Enhanced release of immunoreactive CGRP and substance-P from spinal dorsal horn slices occurs during carrageenan inflammation. *Brain Res* 582:139-142, 1992
  27. Ghoname EA, Craig WF, White PF, Ahmed HE, Hamza MA, Gajraj NM, Vakharia AS, Nohr D: The effect of stimulus frequency on the analgesic response to percutaneous electrical nerve stimulation in patients with chronic low back pain. *Anesth Analg* 88:841-846, 1999
  28. Gopalkrishnan P, Sluka KA: Effect of varying frequency, intensity and pulse duration of TENS on primary hyperalgesia in inflamed rats. *Arch Phys Med Rehabil* 81:984-990, 2000
  29. Han JS, Chen XH, Sun SL, Xu XJ, Yuan Y, Yan SC, Hao JX, Terenius L: Effect of low and high frequency TENS on met-enkephalin-arg-phe and dynorphin A immunoreactivity in human lumbar CSF. *Pain* 47:295-298, 1991
  30. Han JS, Chen XH, Sun SL, Xu XJ, Yuan Y, Yan SC, Hao JX, Terenius L: Effect of low and high frequency TENS on met-enkephalin-arg-phe and dynorphine A immunoreactivity in human lumbar CSF. *Pain* 47:295-298, 1991
  31. Hughes GS, Lichstein PR, Whitlock D, Harker C: Response of plasma beta-endorphins to transcutaneous electrical nerve stimulation in healthy subjects. *Phys Ther* 64:1062-1066, 1984
  32. Indergand HJ, Morgan BJ: Effects of high frequency transcutaneous electrical nerve stimulation on limb blood flow in healthy humans. *Phys Ther* 74:361-367, 1994
  33. Jadad AR, Moore RA, Carroll D, Jenkinson C, Reynolds DJ, Gavaghan DJ, McQuay HJ: Assessing the quality of reports of randomized clinical trials: Is blinding necessary? *Control Clin Trials* 17:1-12, 1996
  34. Jadad A: *Randomised Controlled Trials, a User's Guide*. London, UK, BMJ Books, 1998
  35. Janko M, Trontelj JV: Transcutaneous electrical nerve stimulation a microneurographic and perceptual study. *Pain* 9:219-230, 1980
  36. Johnson MI, Ashton CH, Thompson JW: An in-depth study of long-term users of transcutaneous electrical nerve stimulation (TENS): Implications for clinical use of TENS. *Pain* 44:221-229, 1991
  37. Kalra A, Urban MO, Sluka KA: Blockade of opioid receptors in rostral ventral medulla prevents antihyperalgesia produced by transcutaneous electrical nerve stimulation (TENS). *J Pharmacol Exp Ther* 298:257-263, 2001
  38. Kane K, Taub A: A history of local electrical analgesia. *Pain* 1:125-138, 1975
  39. Kaplan B, Rabinerson D, Lurie S, Bar J, Krieser UR, Neri A: Transcutaneous electrical nerve stimulation (TENS) for adjuvant pain-relief during labor and delivery. *Int J Gynaecol Obstet* 60:251-255, 1998
  40. Kim SH, Chung JM: An experimental-model for peripheral neuropathy produced by segmental spinal nerve ligation in the rat. *Pain* 50:355-363, 1992
  41. King EW, Sluka KA: The effect of varying frequency and intensity of transcutaneous electrical nerve stimulation on secondary mechanical hyperalgesia in an animal model of inflammation. *J Pain* 2:128-133, 2001
  42. Kumar VN, Redford JB: Transcutaneous nerve stimulation in rheumatoid arthritis. *Arch Phys Med Rehabil* 63:595-596, 1982
  43. Lamotte RH, Shain CN, Simone DA, Tsai EFP: Neurogenic hyperalgesia: Psychophysical studies of underlying mechanisms. *J Neurophysiol* 66:190-211, 1991
  44. Lee KH, Chung JM, Willis WD: Inhibition of primate spinothalamic tract cells by TENS. *J Neurosurg* 62:276-287, 1985
  45. Leem JW, Park ES, Paik KS: Electrophysiological evidence for the antinociceptive effect of transcutaneous electrical nerve stimulation on mechanically evoked responsiveness of dorsal horn neurons in neuropathic rats. *Neurosci Lett* 192:197-200, 1995
  46. Ma YT, Sluka KA: Reduction in inflammation-induced sensitization of dorsal horn neurons by transcutaneous electrical nerve stimulation in anesthetized rats. *Exp Brain Res* 137:94-102, 2001
  47. Mannheimer C, Carlsson C-A: The analgesic effect of transcutaneous electrical nerve stimulation (TENS) in patients with rheumatoid arthritis: A comparative study of different pulse patterns. *Pain* 6:329-334, 1979
  48. Mannheimer C, Lund S, Carlsson C-A: The effect of transcutaneous electrical nerve stimulation (TENS) on joint pain in patients with rheumatoid arthritis. *Scand J Rheumatol* 7:13-16, 1978
  49. Marchand S, Charest J, Li J, Chernard JR, Lavignolle B, Laurencelle L: Is TENS purely a placebo effect? A controlled study on chronic low back pain. *Pain* 54:99-106, 1993
  50. Marchand S, Li J, Charest J: Effects of caffeine on anal-

- gesia from transcutaneous electrical nerve stimulation. *N Engl J Med* 333:325-326, 1995
51. Melzack R, Wall PD: Pain mechanisms: A new theory. *Science* 150:971-978, 1965
  52. Milne S, Welch V, Brosseau L, Saginur M, Shea B, Tugwell P, Wells G: Transcutaneous electrical nerve stimulation (TENS) for chronic low back pain. *Chochrane Data Base Syst Rev*, 2001
  53. Moher D, Schulz KF, Altman DG: The CONSORT statement: Revised recommendations for improving the quality of reports of parallel-group randomized trials. *Ann Intern Med* 134:657-662, 2001
  54. Nam TS, Choi Y, Yeon DS, Leem JW, Paik KS: Differential antinociceptive effect of transcutaneous electrical stimulation on pain behavior sensitive or insensitive to phentolamine in neuropathic rats. *Neurosci Lett* 301:17-20, 2001
  55. Neighbors LE, Clelland J, Jackson JR, Bergman J, Orr J: Transcutaneous electrical nerve stimulation for pain relief in primary dysmenorrhea. *Clin J Pain* 3:17-22, 1987
  56. Nolan MF: Selected problems in the use of transcutaneous electrical nerve stimulation for pain control: An appraisal with proposed solutions. A special communication. *Phys Ther* 68:1694-1698, 1988
  57. Osiri M, Welch V, Brosseau L, Shea B, McGowan J, Tugwell P, Wells G: Transcutaneous electrical nerve stimulation for knee osteoarthritis. *Chochrane Data Base Syst Rev*, 2001
  58. Parpura V, Basarsky TA, Liu F, Jeftinija K, Jeftinija S, Haydon PG: Glutamate-mediated astrocyte-neuron signaling. *Nature* 369:744-747, 1994
  59. Price CI, Pandyan AD: Electrical stimulation for preventing and treating post-stroke shoulder pain. *Chochrane Database Syst Rev*, 2000
  60. Proctor ML, Smith CA, Farquhar CM, Stones RW: Transcutaneous electrical nerve stimulation and acupuncture for primary dysmenorrhoea. *Chochrane Database Syst Rev*, 2002
  61. Ren K, Williams GM, Hylden JLK, Ruda MA, Dubner R: The intrathecal administration of excitatory amino-acid receptor antagonists selectively attenuated carrageenan-induced behavioral hyperalgesia in rats. *Eur J Pharmacol* 219:235-243, 1992
  62. Robinson AJ: Transcutaneous electrical nerve stimulation for the control of pain in musculoskeletal disorders. *J Orthop Sports Phys Ther* 24:208-227, 1996
  63. Robinson AJ, Snyder-Mackler L: *Clinical Electrophysiology: Electrotherapy and Electrophysiological Testing* (2nd edition). Baltimore, MD, Williams and Wilkins, 1995
  64. Rokugo T, Takeuchi T, Ito H: A histochemical study of substance P in the rat spinal cord: Effect of transcutaneous electrical nerve stimulation. *J Nippon Med Sch* 69:428-433, 2002
  65. Rosenberg M, Curtis L, Bourke DL: Transcutaneous electrical nerve stimulation for the relief of postoperative pain. *Pain* 5:129-133, 1978
  66. Salar G, Job I, Mingrino S, Bosio A, Trabucchi M: Effect of transcutaneous electrotherapy on CSF  $\beta$ -endorphin content in patients without pain problems. *Pain* 10:169-172, 1981
  67. Salter MW, Henry JL: Evidence that adenosine mediates the depression of spinal dorsal horn neurons induced by peripheral vibration in the cat. *Neuroscience* 22:631-650, 1987
  68. Sato A, Sato A, Schmidt RF: *Impact of Somatosensory Input on Autonomic Functions*. Heidelberg, Germany, Springer, 1997
  69. Schaible HG, Grubb BD: Afferent and spinal mechanisms of joint pain. *Pain* 55:5-54, 1993
  70. Schulz KF, Chalmers I, Hayes RJ, Altman DG: Empirical evidence of bias: Dimensions of methodological quality associated with estimates of treatment effects in controlled trials. *JAMA* 273:408-412, 1995
  71. Sherry JE, Oehrlain KM, Hegge KS, Morgan BJ: Effect of burst-mode transcutaneous electrical nerve stimulation on peripheral vascular resistance. *Phys Ther* 81:1183-1191, 2001
  72. Shimizu T, Koja T, Fujisaki T, Fukuda T: Effects of methysergide and naloxone on analgesia induced by the peripheral electric stimulation in mice. *Brain Res* 208:463-467, 1981
  73. Sjolund BH: Peripheral nerve stimulation suppression of C-fiber evoked flexion reflex in rats. Part 1: Parameters of continuous stimulation. *J Neurosurg* 63:612-616, 1985
  74. Sjolund BH: Peripheral nerve stimulation suppression of C-fiber evoked flexion reflex in rats. Part 2. Parameters of low rat train stimulation of skin and muscle afferent nerves. *J Neurosurg* 68:279-283, 1988
  75. Sjolund BH, Eriksson MBE: The influence of naloxone on analgesia produced by peripheral conditioning stimulation. *Brain Res* 173:295-301, 1979
  76. Sluka KA: Systemic morphine in combination with TENS produces an increased analgesia in rats with acute inflammation. *J Pain* 1:204-211, 2000
  77. Sluka KA, Bailey K, Bogush J, Olson R, Ricketts A: Treatment with either high or low frequency TENS reduces the secondary hyperalgesia observed after injection of kaolin and carrageenan into the knee joint. *Pain* 77:97-102, 1998
  78. Sluka KA, Chandran P: Systemic administration of clonidine in combination with TENS produces an increased antihyperalgesia in rats. *Pain* 100:65-76, 2002
  79. Sluka KA, Deacon M, Stibal A, Strissel S, Terpstra A: Spinal blockade of opioid receptors prevents the analgesia produced by TENS in arthritic rats. *J Pharmacol Exp Ther* 289:840-846, 1999
  80. Sluka KA, Judge MA, McColley MM, Reveiz PM, Taylor BM: Low frequency TENS is less effective than high frequency TENS at reducing inflammation induced hyperalgesia in morphine tolerant rats. *Eur J Pain* 4:185-193, 2000
  81. Sluka KA, Westlund KN: Behavioral and immunohistochemical changes in an experimental arthritis model in rats. *Pain* 55:367-377, 1993
  82. Smith CR, Lewith GT, Machin D: TNS and osteoarthritis: Preliminary study to establish a controlled method of assessing transcutaneous electrical nerve stimulation as a treatment for pain caused by osteoarthritis. *Physiother* 69:266-268, 1983
  83. Solomon RA, Viernstein MC, Long DM: Reduction of postoperative pain and narcotic use by transcutaneous electrical nerve stimulation. *Surgery* 87:142-146, 1980
  84. Somers DL, Clemente FR: High-frequency transcutaneous electrical nerve stimulation alters thermal but not mechanical allodynia following chronic constriction injury of the rat sciatic nerve. *Arch Phys Med Rehabil* 79:1370-1376, 1998
  85. Spielholz NI, Cameron M, Robinson AJ, Snyder-Mackler L, Underwood F, Wicken A: A review of research articles relating to the efficacy of electrical stimulation to alleviate pain

and strengthen muscle: Are insurance companies justified in denying reimbursement for these purposes? Section on Clinical Electrophysiology of the American Physical Therapy Association, 2001. Available at: [www.aptasce.com](http://www.aptasce.com). Accessed September 12, 2002

86. van der Spank JT, Cambier DC, De Paepe HM, Danneels LA, Witvrouw EE, Beerens L: Pain relief in labour by transcutaneous electrical nerve stimulation (TENS). *Arch Gynecol Obstet* 264:131-136, 2000
87. Verdouw BC, Zuurmond WWA, De Lange JJ, Metz GCH, Wagemans MFM: Long-term use and effectiveness of transcutaneous electrical nerve stimulation in treatment of chronic pain patients. *The Pain Clinic* 8:341-346, 1995
88. Verhagen AP, de Bie RA, Lenssen AF, de Vet HCW, Kessels AGH, Boers M, van den Brandt PA: Quality assessment of trials: A comparison of three criteria lists. *Phys Ther Rev* 5:49-58, 2000
89. Verhagen AP, de Vet HC, de Bie RA, Kessels AG, Boers M, Bouter LM, Knipschild PG: The Delphi list: A criteria list for quality assessment of randomized clinical trials for conducting systematic reviews developed by Delphi consensus. *J Clin Epidemiol* 51:1235-1241, 1998
90. Wall PD, Sweet WH: Temporary abolition of pain in man. *Science* 155:108-109, 1967
91. Walsh D: TENS: Clinical Applications and Related Theory. Edinburgh, UK, Churchill Livingstone, 1996
92. Wang B, Tang J, White PF, Naruse R, Sloninsky A, Kariger R, Gold J, Wender RH: Effect of the intensity of transcutaneous acupoint electrical stimulation on the postoperative analgesic requirement. *Anesth Analg* 85:406-413, 1997
93. Warfield CA, Skein JM, Frank HA: The effect of transcutaneous electrical nerve stimulation on pain after thoracotomy. *Ann Thorac Surg* 39:462-465, 1985
94. Wikstrom SO, Svedman P, Svensson H, Tanweer AS: Effect of transcutaneous nerve stimulation on microcirculation in intact skin and blister wounds in healthy volunteers. *Scand J Plast Reconstr Surg Hand Surg* 33:195-201, 1999
95. Willis WD, Coggeshall RE: Sensory Mechanisms of the Spinal Cord (2nd edition) . New York, NY, Plenum, 1991
96. Woolf CJ, Barrett GD, Mitchell D, Myers RA: Naloxone-reversible peripheral electroanalgesia in intact and spinal rats. *Eur J Pharmacol* 45:311-314, 1977
97. Woolf CJ, Mitchell D, Barrett GD: Antinociceptive effect of peripheral segmental electrical stimulation in the rat. *Pain* 8:237-252, 1980
98. Zizic TM, Hoffman KC, Holt PA, Hungerford DS, Odeh JR, Jacobs MA, Lewis CG, Deal CL, Caldwell JR, Cholewcznski JG, Free SM: The treatment of osteoarthritis of the knee with pulsed electrical stimulation. *J Rheumatol* 22:1757-1761, 1995